



Project Document Cover Sheet

Project Information			
Project Acronym	WAMCP		
Project Title	Wellcome Arabic Manuscript Cataloguing Partnership		
Start Date	01/09/2009	End Date	28/02/2011
Lead Institution	Wellcome Library		
Project Director	Richard Aspin, Head of Research and Scholarship, Wellcome Library		
Project Manager & contact details	Christy Henshaw, Wellcome Library, 183 Euston Road, London, NW1 2BE, 020 7611 7333, c.henshaw@wellcome.ac.uk		
Partner Institutions	Bibliotheca Alexandrina, King's College London		
Project Web URL	Pending		
Programme Name (and number)	Islamic Studies Catalogue and Manuscript Digitisation		
Programme Manager	Alastair Dunning		

Document Name			
Document Title	Project Plan		
Reporting Period	n/a		
Author(s) & project role	Christy Henshaw, Project Manager		
Date	29/09/2009	Filename	WAMCP_plan_v3.doc
URL	n/a		
Access	<input checked="" type="checkbox"/> Project and JISC internal		<input type="checkbox"/> General dissemination

Document History		
Version	Date	Comments
1.0	08/2009	First draft.
1.1	01/09/2009	Major edits (CH).
1.2	07/09/2009	Further edits, moved technical info into section 9, GB's tasks and timings added (CH)
2.0	18/09/2009	Further general edits (CH)
3.0	29/09/2009	Integrate BA workpackages, add Gantt chart, other revisions (CH)



JISC Project Plan

Overview of Project

1. Background

The Wellcome Library (WL), Bibliotheca Alexandrina (BA), and King's College London (KCL), have formed a partnership to create, for the first time, a searchable and comprehensive digital collection of Islamic manuscripts in Arabic, to be made freely available on the web. They will also be jointly designing and implementing a cataloguing system which will enable the creation and management of descriptive metadata for Asian manuscripts.

The content consists of ca. 500 Arabic manuscripts dating from the 14th to 20th century, sourced from the Wellcome Library's holdings. This collection is of great interest to scholars of Islamic medicine and science as well as historians of Islam. Making this content available online would be in accord with a key recommendation of the *Exeter report*:¹ the creation of online catalogues of Islamic materials. This report highlighted the Wellcome's efforts with the Haddad catalogue.

The project builds on current work undertaken by the Wellcome Library to digitise its Arabic manuscripts under the auspices of its in-house digitisation programme.

Cataloguers urgently require a system that allows them to capture the full range of character variation that typifies Asian manuscripts, thus enabling researchers to interrogate the resulting metadata in a comprehensive and flexible manner. What is truly lacking for this activity is a system that adequately reflects the specific features of vernacular scripts which are non-standard, such as "dotless" radicals in the Arabic script, the simultaneous use of different vocalizations, rare characters specially invented by medieval authors for phonetic purposes, non-standard abbreviations, and so-called "tree" numbers, to name a few.

Solving these challenges will allow the inclusion of key metadata elements, such as accurate and searchable chapter headings or indeed other minimal divisions for describing texts of a different nature (e.g. poetry). These chapter headings, which medieval Islamic authors tended to standardise throughout their writings, once entered correctly, will allow cataloguers to compare fragments – where the author and title of a work cannot be easily established or are unknown – to the complete works already described. Moreover, enabling searching of specific strings of words such as incipits, for example, including any non-standard characters, will greatly aid such comparison, and will therefore bring even more works to light for further research.

2. Aims and Objectives

The key aim of this project is to provide the Wellcome Library and the Bibliotheca Alexandrina with a means to build, manage and disseminate digital collections of Islamic manuscripts including both metadata and digital images. The objectives of this project are:

- To design and implement an open source cataloguing tool for use by English and Arabic speakers, producing records which comply with the Text Encoding Initiative (TEI) P5 cataloguing schema.
- To create rich descriptive metadata for each manuscript to facilitate resource discovery and enhance understanding of the content and context of the material.

¹ See page 32 of the Exeter report at http://projects.exeter.ac.uk/digiislam/documents/DigiIslamReport_000.pdf.

- To make high quality images of every manuscript available online via the BA's Digital Library and the WL online catalogue.
- To create an appropriate web front-end for search and display of the content to be hosted by the BA.
- To create fully-formed MARC21 records for each intellectual work to facilitate resource discovery via the WL catalogue.

3. Overall Approach

The cataloguing project builds on the experience gained by Nikolai Serikoff at the WL and Gerhard Brey at KCL in creating an online catalogue for a small collection of Arabic manuscripts (the Haddad collection)² based on the TEI P4 and MASTER manuscript description standards. The proposed project will use this intellectual framework and previously developed technology for the existing manuscript catalogue as the basis for the new software development and delivery.

There are three elements to this project:

- 1) the creation of the cataloguing tool and workflows that enable its use
- 2) creating catalogue records – based on the TEI P5 schema – for the ca. 500 manuscripts identified in this project . Part of this will involve converting the existing metadata to this new schema, and the export of MARC21 records for the WL OPAC.
- 3) delivery of metadata and images to users

The WL's own digitisation programme will see the conservation and digitisation of the 500 manuscripts included in this project. The result of digitisation will be c. 75,000 images to be displayed alongside the descriptive metadata. Digitisation will be completed at the end of 2009.

3.1 Cataloguing tool.

The WL will work closely with KCL and the BA in developing a cataloguing tool and workflow processes that will enable these manuscripts to be catalogued for efficient resource discovery purposes. KCL will advise and direct the creation of detailed specifications that build on the existing Haddad system described above, with input from the BA's ICT department. The BA will carry out the technical development work required in-house using existing technical development staff. Documentation and use guidelines will be created jointly by KCL and BA, with KCL leading.

3.2 Cataloguing.

Cataloguing of the 500 manuscripts will be carried out jointly by the WL and the BA. Manuscripts which are currently unidentifiable, or in a very fragile condition are excluded from the project.

The proposed cataloguing methodology follows a tripartite system for describing manuscripts. Each manuscript is considered as a museum object, an intellectual item, and as a subject of human activity over the lifetime of the object. This will provide a comprehensive description enabling search and discovery, understanding of creation, context and use, and facilitate analysis of writing styles. It will also allow the identification of fragments by matching chapter/section headings to the known works catalogued in this project.

Physical description of the manuscripts will be carried out at the WL, as well as cataloguing of certain aspects of the textual content requiring expert interpretation.

The cataloguing team at the BA will - using the digital images to describe certain aspects of the textual content including recording the chapter headings (for a selected sample of manuscripts) and other textual aspects of the work that will enable contextualisation and enhanced searching.

² See <http://library.wellcome.ac.uk/node273.html>.

Cataloguing will be carried out using an input interface built-in to the cataloguing system described above. The details of this will be described in the technical specifications (workpackage 1). For an overview of the cataloguing workflow see Figure 1, below.

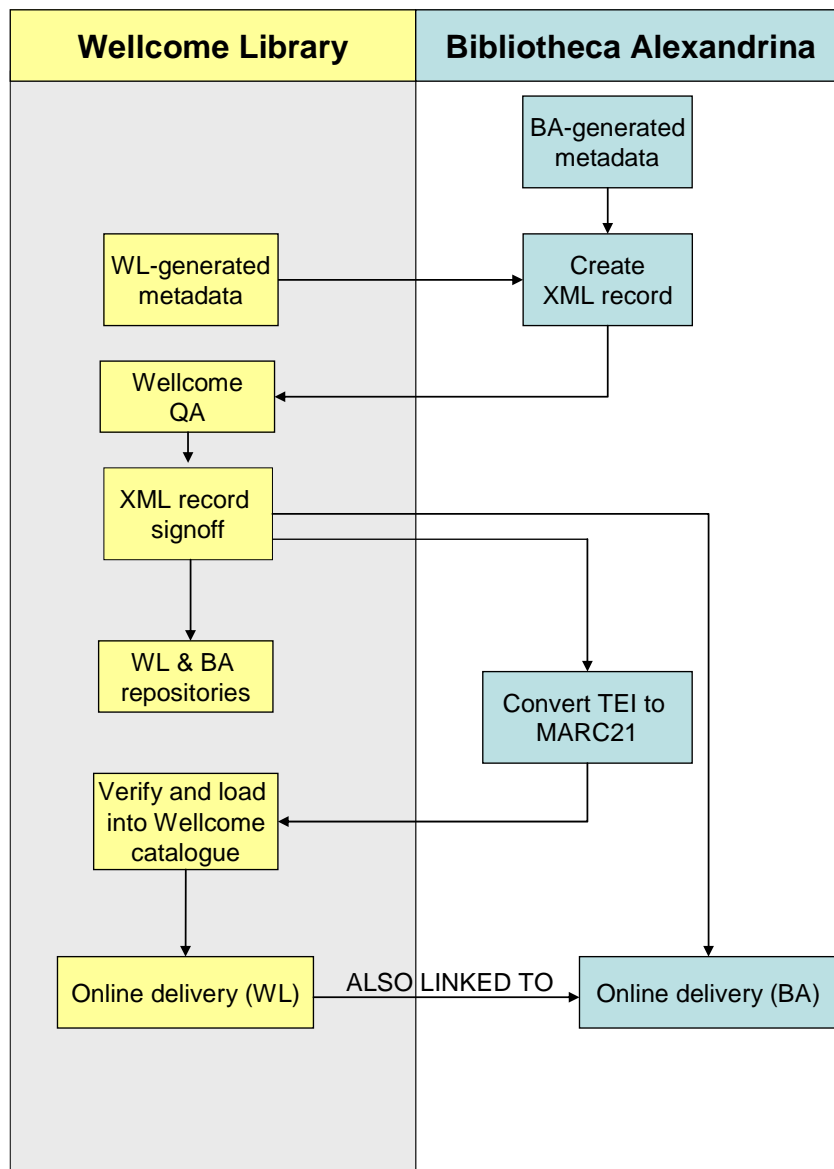

Figure 1. Cataloguing methodology – workflow diagram.

3.3 Delivery.

There will be two points of access to the metadata and images created by this project:

- 1) A dedicated website hosted by the BA, which will provide the functionality to search the full metadata set and display the digital images. Metadata and images will be stored by the BA for this purpose.
- 2) Access to metadata records and images via the WL online catalogue. The full metadata and image outputs will be stored by the WL for this purpose.

Project Acronym: WAMCP
Version: 3.0
Contact: Christy Henshaw, c.henshaw@wellcome.ac.uk
Date: September 2009

The BA will lead on the specification, design and technical development/implementation of the website, using existing in-house programmers and website designers, with advise and input from KCL and the WL. The BA will host the website, and sustain it in the long term, proving free worldwide access to the content under a Creative Commons license.

3.4 Critical success factors.

The success of the project will rest primarily on good communication between partners and acting on constructive feedback, particularly in the following areas:

- Specifications are comprehensive and detailed enough to clearly express technical requirements.
- Technical development is carried out in a timely manner.
- Quality control of technical work.
- Quality control of metadata.
- Usability of website.

4. Project Outputs

- Technical specifications.
- Cataloguing guidelines.
- Cataloguing tool.
- Catalogue tool user guidelines.
- TEI XML catalogue records for 500 mss.
- MARC21 catalogue records for 500 mss.
- PDF versions of XML catalogue records.
- Online dissemination tool (website).
- Evaluation report (summative).
- Project progress reports.
- Consortium agreement.
- Establish best-practices for electronic Asian manuscript cataloguing.

5. Project Outcomes

5.1 A specialised cataloguing system for Islamic manuscripts.

This will encourage a uniform cataloguing standard that will provide remote access to Islamic manuscripts via rich metadata and associated digital images.

5.2 Online access to rich metadata and cover-to-cover images.

Descriptive records for the 500 manuscripts will greatly facilitate resource discovery and in-depth research enhancing understanding of the content and context of the material.

5.3 Developments in Islamic manuscript cataloguing.

This project will enable all partners to set a new precedent for best practices in the cataloguing of Asian manuscripts – the type/amount of metadata to capture in order to facilitate serious scholarly research for all core stakeholders, the management of that metadata to ensure long-term relevancy, and the provision of that metadata in useful and engaging ways.

6. Stakeholder Analysis

Stakeholder	Interest / stake	Importance
Scholars of Arabic medicine, science and history; Islamic studies specialists; conservators	Require access to primary materials to carry out research activities.	High
Cataloguing professionals – in particular those working at the BA and Wellcome	Will use the proposed system to input and manage metadata.	High
Non-specialist audiences and general public	Access to the educational benefits of the project	Low
Wellcome Trust/ Wellcome Library	Project partner and funder, hosting content	High
JISC	Funder	High
Bibliotheca Alexandrina	Project partner, hosting content	High
King's College London	Project partner	Medium

7. Risk Analysis

Risk	Probability (1-5)	Severity (1-5)	Score (P x S)	Action to Prevent/Manage Risk
Staffing – loss of staff causing delay to project deliverables	4	5	20	Use of institutional recruitment processes. Documentation for efficient induction of new staff.
Organisational - Overruns not covered by existing budget; deadlines not met.	2	5	10	Close communication with all parties to set achievable timescales and costs for all aspects of the project. Contribution by all partners to technical specifications.
Technical - software does not meet needs of users.	2	5	10	Close communication between all partners, bringing together a range of expertise. Clear specification of requirements. Open dialogue with professional and academic networks. Extensive testing. User feedback at an early stage.
Technical – website does not meet needs of users	3	4	12	Clear specification of requirements. User feedback on website design and display of content at an early stage. Extensive testing.
Quality of metadata - Metadata is not suitable or accurate.	2	5	10	Careful recruitment of cataloguing staff; use of accepted cataloguing standards. Liaison with the professional community. Use of expert reviewers.
Quality of images – images are not suitable or accurate.	2	5	10	Use of WL's existing imaging QA procedures. Communication with BA on required image specifications.

8. Standards

Name of standard or specification	Version	Notes
Text Encoding Initiative (TEI) XML	P5	Metadata for searchable database. A new schema will be developed as part of the project, but TEI P5 guidelines will be adhered to.
OCLC bibliographic authorities		To be used where present.
MARC21		Metadata for Wellcome Library catalogue.
AARC2		Metadata for Wellcome Library catalogue
JPEG2000	Part 1	Visually lossless .jp2 format for long-term preservation of digital images. This forms part of the WL's strategy to store high-quality image files whilst minimising storage requirements for large digitisation projects. The BA will be storing mathematically lossless .jp2 files as part of the BA's digital preservation strategy.
PDF	7.0	PDF documents of rich XML data will be attached to WL OPAC.

9. Technical Development

9.2. Cataloguing tool

This software system will be optimised for use by both English and Arabic speakers, allowing the full description of Arabic language materials and storing the metadata as TEI-compliant XML documents. This is aimed at improving the current state of Arabic (and other Asian language) manuscript cataloguing data. Such a system must cater for these language and material-specific requirements, but also meet the wider needs of the community by providing a metadata repository that:

- Is standards-based
- Is adaptable
- Is fully-searchable
- Is affordable
- Is easy to use
- Is scaleable
- Is portable
- Is adaptable for retroconversion of hard copy catalogues
- Can provide access to image content

The key requirements (to be finalised in a detailed specifications document during workpackage 1) for the cataloguing software tool are as follows:

- **Data repository** – this concerns the ingest of existing metadata, and issues surrounding the use of the TEI P5 schema, UNICODE and export of data to other standards. This will be hosted initially by the BA, but the Wellcome Library plans to integrate the database into its own digital library in future.
 - Creation of TEI P5 (msDescription) -based XML schema³.

³ Released on November 1, 2007; see TEI P5 Guidelines (<http://www.tei-c.org/Guidelines/P5/>); "From MASTER to TEI P5" (<http://tei.oucs.ox.ac.uk/ENRICH/Deliverables/WP3-00.1.0.xml>)

- Creation of a conversion programme from TEI P4 MASTER and ArabTeX to the new schema.
- Identify non-UNICODE characters specific to medieval Arabic manuscripts and manage their input and display.
- Investigate problems/issues related to the storage, input and display of bi-directional UNICODE text.
- Create export facilities to the WL's Encore system (XML) and OPAC (MARC21).
- **Input system** – this will be the web-based user interface for administration, data input and QA.
 - Design and build a web-based interface with template for data entry, and a facility to handle the non-UNICODE characters.
 - Develop a workflow for data input.
 - Create a facility to input Arabic characters (including non-standard characters) via a virtual keyboard and/or a transliteration scheme.

The cataloguing system – via an automatic conversion routine - will enable the export of MARC21 records to AARC standards. This will facilitate resource discovery and retrieval of the original objects via the Library's OPAC.

9.3. Website

The addition of high-quality images of entire manuscripts, including details of the coverings, will greatly improve access to both the text of the manuscripts as well as the physical structure of the objects. Images will be made available via the BA's dedicated website, and WL's OPAC. Targeted searching to chapter heading level for a sample of around 200 manuscripts on the BA's website will enable the researcher to go straight to images containing the relevant chapter heading or folio required for ease of reference. Images will be stored in the long term at both the WL and the BA.

10. Intellectual Property Rights

The Wellcome Library owns the rights of all digital images created for this project. The metadata, software and website rights will be jointly owned by the WT and the BA.

Outputs/components	IPR owner(s)
Digital images	Wellcome Trust
Metadata	Wellcome Trust and Bibliotheca Alexandrina
Cataloguing software	Wellcome Trust and Bibliotheca Alexandrina
Online dissemination tool (web front end)	Wellcome Trust and Bibliotheca Alexandrina

Project Resources

11. Project Partners

- **Wellcome Library**
Lead partner; supply of images; project management and directorship of the project; cataloguing; cataloguing QA; making images and descriptive metadata available on the Wellcome Library website.
Primary contact: Christy Henshaw, Digitisation Project Manager

- Bibliotheca Alexandrina**
 Technical development, testing, and implementing software system; designing and hosting a dedicated website; cataloguing; cataloguing QA; long-term preservation and management of metadata and images.
Primary contact: Professor Magdy Nagi, Head of ICT Sector
- King's College London**
 Expert advice and creation of technical specifications; design and implement a suitable XML schema for metadata management; expert input on web site design.
Primary contact: Gerhard Brey, Fellow, KCL.

12. Project Management

The project manager is Christy Henshaw, who will be spending 40% full time on the project during most of the 18 month duration. Table 2, below, lists the project team members. See Annex C for contact details.

A **Project Board** has overall responsibility for the success of the project. Representatives from all partners, the project manager, the JISC Programme Manager and the Chair of the Project Advisory Committee sit on this Board (see Table 1, below). This Board will meet four times during the course of the project.

A **Project Advisory Committee**, consisting of both internal and external members, provides advice to the Project Board, and facilitates dissemination of project outcomes. This committee will meet four times during the course of the project in advance of the Project Board.

An **Operational Board** manages the day-to-day activities and task-specific teams, reports to the Project Board, and liaises with the Project Advisory Board. Membership consists of key project staff from all three partners, and additional members may be co-opted from any of the three partners as and when necessary. This Board meets monthly throughout the project.

<p>Project Board</p> <p>Role: Oversight of the project and high-level decision making.</p> <p>Members:</p> <ul style="list-style-type: none"> Richard Aspin, Head of Research and Scholarship (WL, Chair) Christy Henshaw, Digitisation Project Manager (WL, Secretary) Magdy Nagi, Professor and Head of ICT (BA representative) Simon Tanner, Director of KDCS, (KCL representative) Alastair Dunning (JISC representative) (Chair of Project Advisory Committee)
<p>Project Advisory Committee</p> <p>Role: To provide advice on key project decisions and facilitate dissemination of project outcomes.</p> <p>Reports to: Project Board</p> <p>Members (internal):</p> <ul style="list-style-type: none"> Richard Aspin, Head of Research and Scholarship (WL) Nikolai Serikoff, Librarian (Asian collections, WL) Christy Henshaw, Digitisation Project Manager (WL, Secretary) Noha Adly, Deputy Head ICT Sector (BA) <p>Four external members (to be confirmed)</p>

Operational Board
Role: To plan and manage cataloguing tool development, cataloguing and website design.
Reports to: Project Board
Members:
<ul style="list-style-type: none"> • Christy Henshaw, Digitisation Project Manager (Chair, WL) • Nikolai Serikoff, Librarian, Asian collections (WL) • Gerhard Brey, Fellow (KCL) • Magdy Nagi, Professor and Head of ICT (BA) • Youssef Ziedan, Professor (BA) • June Tomlinson, Cataloguing and Metadata Services Manager (WL)

Table 1. Project governance.

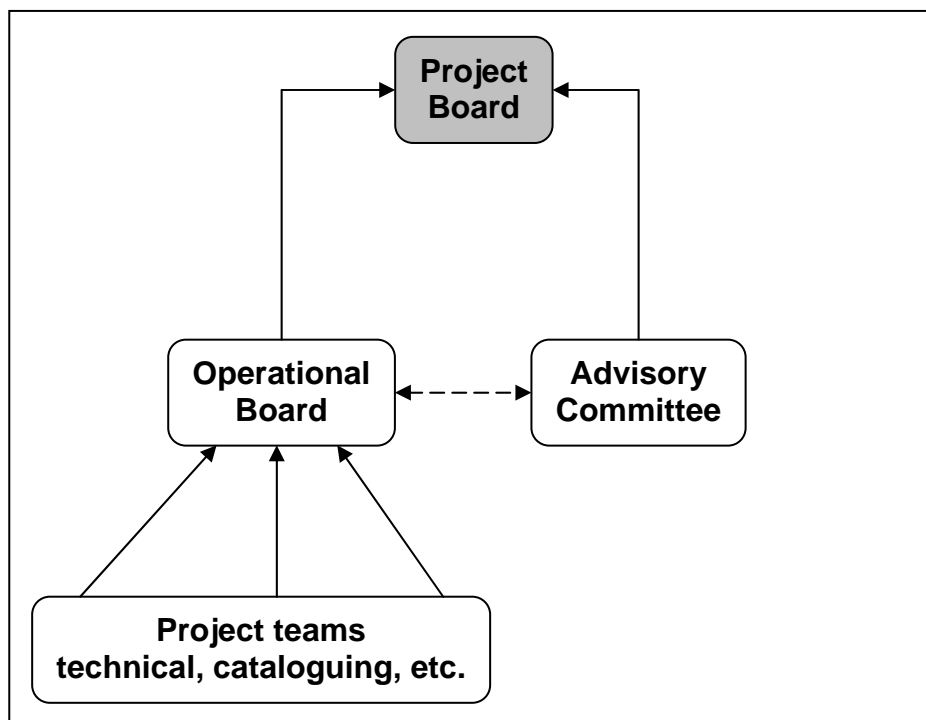

Figure 2. Project governance diagram.

Name	Responsibilities	Location
Richard Aspin	Project Director. Chair of Project Board.	WL
Nikolai Serikoff	Produces cataloguing guidelines; cataloguing; advises on cataloguing efforts of BA cataloguers; QA catalogue records; involved in writing specifications for cataloguing tool and website.	WL
Christy Henshaw	Manage project; produce project plan and progress reports; manage communication between partners; secretary to Advisory Committee and Project Board.	WL
June Tomlinson	Oversees MARC 21 cataloguing and implementation of mapping from XML to MARC21; QA MARC records and load into WL catalogue.	WL
Laurie	Under auspices of separate digitisation project,	WL

Auchterlonie	making sure images are transferred to the BA.	
Simon Tanner	Project director for KCL elements.	KCL
Gerhard Brey	Produces specifications for cataloguing tool and the user guidelines; expert advice on implementation and use of the software; expert advice on the development of the website.	KCL
Magdy Nagi	Project director for BA elements. Oversees all technical development and implementation.	BA
Noha Adly	Oversees all technical development and implementation.	BA
Youssef Ziedan	Oversees cataloguing work of BA cataloguers	BA
Technical development technicians (220 days)	Design and implementation of cataloguing tool, back-end database and front-end input interface	BA
Web designers (38 days)	Design, implement and manage the website at BA.	BA
Technical support engineers (76 days)	Manage technical infrastructure elements.	BA
IT technicians (95 days)	Testing and QA of all technological developments; processing digital files and creation of derivatives	BA
System and network administrators (114 days)	System and network administration to support technical development.	BA
Cataloguers (570 days)	Cataloguing into TEI XML.	BA
Cataloguing editor	QA catalogue records.	BA
Cataloguing supervisor	Day-to-day supervision of the cataloguing team.	BA

Table 2. Project team members.

13. Programme Support

Ad hoc advice on JISC Programme reporting requirements via the Programme Manager.

14. Budget

See Appendix A.

Detailed Project Planning

15. Workpackages

See Appendix B and D.

16. Evaluation Plan

Timing	Factor to Evaluate	Questions to Address	Method(s)	Measure of Success
Mar 2010	Cataloguing tool	<ul style="list-style-type: none"> - Timely completion - Meets quality standards - Fit for purpose 	<ul style="list-style-type: none"> - Review by all project management committees - User testing - Check against accepted standards - Compare to specifications 	<ul style="list-style-type: none"> - Reviewers' approval - Adheres to specification of requirements - Adheres to accepted quality standards - User feedback/sign-off
May 2010	Cataloguing	<ul style="list-style-type: none"> - Adheres to cataloguing guidelines - Progress - Quality 	<ul style="list-style-type: none"> - Project targets - QA reports 	<ul style="list-style-type: none"> - Targets met - minimum quality standards are met
Jul 2010	Website (test site)	<ul style="list-style-type: none"> - Meets quality standards - Fit for purpose 	<ul style="list-style-type: none"> - Review by all project management committees - User testing - Check against accepted standards - Compare to specifications 	<ul style="list-style-type: none"> - Reviewers' approval - Adheres to specification of requirements - Adheres to accepted quality standards - User feedback/sign-off
Mar 2011	Overall project success	<ul style="list-style-type: none"> - Meets project aims - Value-for-money - Timely completion of deliverables/outcomes - Sustainable 	<ul style="list-style-type: none"> - Formal evaluation (outsourced) 	<ul style="list-style-type: none"> - Formal evaluation report

17. Quality Plan

Output	Cataloguing software tool				
Timing	Quality criteria	QA method(s)	Evidence of compliance	Quality responsibilities	Quality tools (if applicable)
01/10-03/10	Meets quality standards	Clear specification of requirements; periodic review of progress	Checklist of quality standards met	Magdy Nagi (BA)	

Output		Metadata			
Timing	Quality criteria	QA method(s)	Evidence of compliance	Quality responsibilities	Quality tools (if applicable)
03/10 – 01/11	Accuracy and complete-ness	Clear cataloguing guidelines; regular checking by cataloguing professionals	Metadata QA reports; signoff by Wellcome Library	Nikolai Serikoff (WL)	
03/10 – 01/11	Valid standards / formats for XML documents	Automatic storage routines in software; programmatic validation	Acceptance by validation routines; signoff by Wellcome Library	Nikolai Serikoff (WL)	XML validation tool
04/10 – 01/11	Valid standards / formats for MARC21 / AACR2 data	Automatic conversion routines in software; programmatic validation	Acceptance by validation routines; signoff by Wellcome Library	June Tomlinson (WL)	MARC21 validation tool
Output		Website			
Timing	Quality criteria	QA method(s)	Evidence of compliance	Quality responsibilities	Quality tools (if applicable)
03/10-07/10	Meets quality standards (WC3 recommendations)	WC3 validation	Acceptance by validation routines	Magdy Nagi (BA)	WC3 validation tool

18. Dissemination Plan

Timing	Dissemination Activity	Audience	Purpose	Key Message
September 2009	Press release (blog, mailing lists)	The research and cataloguing community	Raise awareness	Project aims and objectives, key deliverables
September 2009	Copy for JISC project website	The research and cataloguing community	Raise awareness	As above
November 2009	Project website at lead institution	The research and cataloguing community	Raise awareness; over time, to inform	As above, also communicating progress
June 2010	Presentation/demonstration of cataloguing tool and cataloguing methods (London & Alexandria)	The research and cataloguing community	Inform, engage, promote	Successful completion of cataloguing tool, how it can be used and extended
November 2010	Presentation/demonstration of website and research capabilities (London & Alexandria)	The research and cataloguing community	Inform, engage	Facilitating research

January 2011	Launch and demonstration (London & Alexandria)	Stakeholders, key members of the research and cataloguing community	Promote	Success of project, benefits to community
February 2011	Press release	The research and cataloguing community	Raise awareness, promote	As above

19. Exit and Sustainability Plans

Project Outputs	Action for Take-up & Embedding	Action for Exit
Catalogue data and image content	Make freely accessible online via both BA website and WL OPAC	Continue providing access in the long term
Software tool	Make available on Sourceforge; provide documentation in its use and implementation	Upload application and documents to Sourceforge
Online dissemination tool	Access freely available to all	Continue providing access in the long term

Project Outputs	Why Sustainable	Scenarios for Taking Forward	Issues to Address
Catalogue data	The catalogue data underpins the ability to discover and understand the collection (both physical and digital)	Ensure long-term free online access; promote of the resource to the relevant communities; continue to add and develop the metadata in future	Resource for adding to the database relevant works that were out of scope for the current project and continuing to add chapter headings beyond the sample set.
Software tool	The tool is intended to be a long-term catalogue management system	Continued development as appropriate	Resource for any development needs that may arise.
Online dissemination tool	The website is intended to be a long-term point of access for academics and researchers	Hosting by BA digital library; continued development as appropriate	Resource for any development needs that may arise.

Nature of institutional contributions

Directly incurred staff	Year 1	Year 2	Total
[REDACTED]	[REDACTED]	[REDACTED]	[REDACTED]
[REDACTED]	[REDACTED]	[REDACTED]	[REDACTED]
[REDACTED]	[REDACTED]	[REDACTED]	[REDACTED]
[REDACTED]	[REDACTED]	[REDACTED]	[REDACTED]
[REDACTED]	[REDACTED]	[REDACTED]	[REDACTED]
[REDACTED]	[REDACTED]	[REDACTED]	[REDACTED]
[REDACTED]	[REDACTED]	[REDACTED]	[REDACTED]
[REDACTED]	[REDACTED]	[REDACTED]	[REDACTED]
[REDACTED]	[REDACTED]	[REDACTED]	[REDACTED]
[REDACTED]	[REDACTED]	[REDACTED]	[REDACTED]
[REDACTED]	[REDACTED]	[REDACTED]	[REDACTED]
[REDACTED]	[REDACTED]	[REDACTED]	[REDACTED]
[REDACTED]	[REDACTED]	[REDACTED]	[REDACTED]
[REDACTED]	[REDACTED]	[REDACTED]	[REDACTED]
[REDACTED]	[REDACTED]	[REDACTED]	[REDACTED]
[REDACTED]	[REDACTED]	[REDACTED]	[REDACTED]
[REDACTED]	[REDACTED]	[REDACTED]	[REDACTED]
[REDACTED]	[REDACTED]	[REDACTED]	[REDACTED]
[REDACTED]	[REDACTED]	[REDACTED]	[REDACTED]
[REDACTED]	[REDACTED]	[REDACTED]	[REDACTED]

Appendix B. Workpackages

Dependencies are shown by the number of the relevant task.

WORKPACKAGES	1	2	3	4	5	6	7	8	9	10	11	12	13	14	15	16	17	18	19	20	21	22	23	24
YEAR	2009				2010												2011							
MONTH	S	O	N	D	J	F	M	A	M	J	J	A	S	O	N	D	J	F	M	A	M	J	J	A
1: Preparatory work	■	■	■	■	■		■																	
2: Software SoR		■	■	■	■																			
3: Produce software					■	■	■																	
4: XML cataloguing								■	■	■	■													
5: MARC21 cataloguing									■	■	■	■	■	■	■	■								
6: QA catalogue data									■	■	■	■	■	■	■	■	■							
7: Website SoR							■	■																
8: Produce website									■	■	■	■												
9: Ingest, display content													■	■	■	■	■	■						
10: Project documents	■	■								■							■	■	■					
11: Proj. Board meetings				■				■									■							
12: Project website	■	■	■																					
13: Dissemination	■	■	■	■	■	■	■	■	■	■	■	■	■	■	■	■	■	■	■	■	■			
14: Evaluation						■				■									■	■	■			

Project start date: 01 September 2009

Project completion date: 26 February 2011

Duration: 18 months

<i>Workpackage and activity</i>	Earliest start date	Latest completion date	Outputs (clearly indicate deliverables & reports in bold)	Milestone	Responsibility
---------------------------------	---------------------------	------------------------------	--	-----------	----------------

YEAR 1				Milestone	Responsibility
<p>WORKPACKAGE 1: Preparatory work</p> <p><u>Objective:</u> To prepare the existing metadata and create cataloguing guidelines.</p>	01/09/09	26/03/10	Preparatory work completed.		GB NS CH LA
1. Develop the TEI P5 schema	01/09/09	16/10/09	Valid TEI P5 schema		GB/NS
2. Provide design specifications for conversion of existing TEI P4 MASTER and ArabTeX manuscript descriptions to TEI P5 conformant descriptions	19/10/09	20/11/09	Specifications document		GB/NS
3. Adapt existing conversion program	23/11/09	25/11/09	Program written		GB
4. Convert TEI MASTER and ArabTeX metadata to TEI P5 schema	26/11/09	27/11/09	Set of 120 converted records to new TEI P5 schema		GB
5. Provide comprehensive guidelines for cataloguing methodology	28/09/09	27/11/09	Cataloguing guidelines		NS
6. Project board sign off cataloguing guidelines	17/12/09	17/12/09	Cataloguing guidelines approved		Project board
7. Transfer images to BA	11/01/10	26/03/10	All images transferred to BA		LA/CH
<p>WORKPACKAGE 2: Produce specification of requirements for cataloguing tool.</p> <p><u>Objective:</u> Clear and comprehensive specifications document for cataloguing tool.</p>	01/10/09	17/12/09	Completed specifications document approved by Project Board		GB NS JT
8. Write the catalogue tool specifications, including:	01/10/09	17/12/09	Technical specification of requirements		
9. Determine mechanism for displaying non-standard characters and bi-directional text.	01/10/09	17/12/09	Preferred solution documented		GB/NS

<i>Workpackage and activity</i>	Earliest start date	Latest completion date	Outputs (clearly indicate deliverables & reports in bold)	Milestone	Responsibility
---------------------------------	---------------------------	------------------------------	--	-----------	----------------

10. Design mapping table for export to Encore XML and MARC21	01/10/09	17/12/09	Mapping table		GB/NS/JT
11. Describe the requirements for implementing controlled access to the repository	01/10/09	17/12/09	Specification of requirements for access control		GB/MN
12. Describe the requirements for the storage backend.	01/10/09	17/12/09	Specification of requirements for storage backend		GB/MN
13. Project board signs off specification	17/12/09	17/12/09	Specification approved		Project Board
WORKPACKAGE 3: Produce cataloguing tool software <u>Objective:</u> to produce an operational cataloguing tool	18/01/10	27/03/10	Cataloguing software package.		MN
14. Design a database structure for the TEI P5 schema	18/01/10	27/03/10	Database back-end		MN
15. Implement a tool for cataloguers acting as a virtual keyboard that allows adding and editing standard and non-standard Arabic characters	18/01/10	27/03/10	Data entry front-end		MN
16. Implement cataloguing tool according to specifications	18/01/10	27/03/10	Software approved by Project Board		MN
17. Integrate converted records into the new system	29/03/10	30/03/10	Base repository		MN
18. Carry out QA and testing	18/01/10	27/03/10	Cataloguing tool approved by Project Board		MN
WORKPACKAGE 4: XML cataloguing <u>Objective:</u> Create TEI P5-compliant XML documents.	29/03/10	30/10/10	TEI P5-compliant catalogue records for 400 manuscripts.		NS YZ
19. Enter basic descriptions	29/03/10	23/07/10	Completed basic descriptions for each manuscript		YZ

<i>Workpackage and activity</i>	Earliest start date	Latest completion date	Outputs (clearly indicate deliverables & reports in bold)	Milestone	Responsibility
20. Enter physical descriptions	29/03/10	23/07/10	Completed physical descriptions for each manuscript		NS
21. Enter chapter headings	26/07/10	30/10/10	Completed chapter heading transcription for selected priority manuscripts		YZ
WORKPACKAGE 5: MARC21 cataloguing <u>Objective:</u> Create well-formed MARC21 records using automatic conversion routines.	03/05/10	26/07/10	MARC21 records for 500 manuscripts available.		MN JT
22. Implement conversion tool to produce MARC21 records	03/05/10	23/07/10	MARC21 records successfully created		BA
23. Run export routine to produce MARC21 records	04/05/10	24/07/10	MARC21 records successfully exported		BA
24. Transfer MARC21 records to WL	04/05/10	24/07/10	MARC21 records receipt confirmed by WL		JT
25. Validate and load MARC21 records to WL catalogue	05/05/10	26/07/10	MARC21 records validated and successfully loaded		JT
WORKPACKAGE 6: QA catalogue records <u>Objective:</u> Carry out QA of all metadata and sign off deliverables.	29/03/10	15/01/11	All metadata signed off as complete and accurate according to QA procedures and quality thresholds.		YZ NS JT
26. Editorial QA and signoff of BA-produced metadata	29/03/10	30/11/2010	Draft QA reports		YZ
27. High-level QA and signoff of all XML metadata	29/03/10	15/01/11	Final QA reports		NS
WORKPACKAGE 7: Produce specification of requirements for website <u>Objective:</u> Clear and comprehensive specifications document for website/web delivery.	01/03/10	14/05/10	Completed specifications document		MN NS GB

<i>Workpackage and activity</i>	Earliest start date	Latest completion date	Outputs (clearly indicate deliverables & reports in bold)	Milestone	Responsibility
---------------------------------	---------------------------	------------------------------	--	-----------	----------------

28. Produce specification of requirements document, including:	01/03/10	14/05/10	Specification of requirements		MN/NS/GB
29. Specification of virtual keyboard for input of Arabic characters on non-Arabic keyboards	01/03/10	14/05/10	Specification of virtual keyboard		GB/MN
30. Specification of image viewing options (individual folios, chapter headings, etc.)	01/03/10	14/05/10	Specification of image viewing options		NS/GB/MN
31. Specification of display options to enable varying degrees of detail for metadata viewing	01/03/10	14/05/10	Specification of metadata viewing options		NS/GB/MN
32. Development of a stable citation system	01/03/10	14/05/10	Citation system		GB/MN
33. Describe requirements to ensure interoperability with other online catalogues	01/03/10	14/05/10	Interoperability		GB/MN
34. Describe requirements for printing facility	01/03/10	14/05/10	Specification of printing facility		GB/MN
35. Project board signs off SoR	14/05/10	14/05/10	Specification approved		Project board
WORKPACKAGE 8: Produce website Objective: Design, test and publish the Arabic manuscript catalogue website.	17/05/10	06/09/10	Arabic manuscript catalogue website publicly accessible at the BA.		MN
36. Develop wireframes for the final structure design and for the system functionalities to be implemented	17/05/10	31/05/10	Wireframes approved by Operational Board		MN
37. Design and Implement an image viewer for the manuscript digital images using Image Service techniques	01/06/10	05/07/10	Image viewer		MN
38. Design and implement a simple virtual keyboard to be used by the public for searching Arabic terms using standard and non-standard Arabic characters	01/06/10	05/07/10	Virtual keyboard		MN
39. Design and implement a tool for display of metadata with different levels of details	01/06/10	05/07/10	Metadata display system		MN
40. Develop various browsing techniques according	01/06/10	05/07/10	Search functions		MN/NS

<i>Workpackage and activity</i>	Earliest start date	Latest completion date	Outputs (clearly indicate deliverables & reports in bold)	Milestone	Responsibility
---------------------------------	---------------------------	------------------------------	--	-----------	----------------

to metadata classifications					
41. Develop a search engine for metadata (simple and advanced)	01/06/10	05/07/10	Search interface		MN
42. Provide alternatives for graphic design interface	01/06/10	05/07/10	Graphic interface		MN
43. Integrate the graphic design with the implemented system	06/07/10	09/08/10	System integration		MN
44. Provide a prototype with sample data for testing	09/08/10	09/08/10	Approved by Program Board		MN
45. Test operability with sample content	10/08/10	16/08/10	Operability proven		MN
46. Seek feedback from user community	10/08/10	23/08/10	Feedback report		MN/CH
47. Final website refinement	24/08/10	06/09/10	Website completed		MN
48. Website, with sample content, goes live	06/09/10	06/09/10	Website available to public		MN
<i>WORKPACKAGE 9: Ingest and display content</i> Objective: Ingest and display existing content (images and metadata), and continue loading new content in batches until cataloguing finishes	07/09/10	08/03/11	All content is available online.		MN
49. Ingest backlog and make available online	07/09/10	05/10/10	All current completed deliverables available online		MN
50. Carry out archiving of images and metadata	07/09/10	08/03/10	All content created during course of the project is available online		MN
<i>WORKPACKAGE 10: Project documents</i> Objective: Administer project workflows and track progress, report to project committees, etc.	01/10/09	28/02/11	Project documents		CH
51. Produce project plan	01/10/09	01/10/09	Project Board and JISC-approved project plan		CH
52. Sign consortium agreement	30/10/09	30/10/09	Consortium Agreement signed by all partners		CH

<i>Workpackage and activity</i>	Earliest start date	Latest completion date	Outputs (clearly indicate deliverables & reports in bold)	Milestone	Responsibility
---------------------------------	---------------------------	------------------------------	--	-----------	----------------

53. JISC Progress report	15/06/11	15/06/11	Progress report approved by JISC		CH
54. JISC Final report	21/02/11	21/02/11	Final report approved by JISC		CH
55. JISC Completion report	28/02/11	28/02/11	Completion report approved by JISC		CH
<i>WORKPACKAGE 11: Project Board meetings</i> Objective: Key decision-making and guidance for project teams.	10/09	12/09	Minutes of meetings.		RA CH
56. Project Board meeting December 09	12/09	12/09	Minutes		RA/CH
57. Project board meeting April 10	04/10	04/10	Minutes		RA/CH
58. Project Board meeting January 2011	01/11	01/11	Minutes		RA/CH
<i>WORKPACKAGE 11: Project information website</i> Objective: Create and host a project information website at the Wellcome Library	01/09/09	02/12/09	Project website available		CH
59. Commission web design from in-house web team	01/09/09	01/09/09	Agreement on wireframe.		CH
60. Develop wireframe	01/10/09	15/10/09	Wireframe established		CH
61. Write website content	16/10/09	02/11/09	Copy approved by editorial team		CH
62. Web team creates website	03/11/09	02/12/09	Draft website approved by Operational Board		CH
63. Website live	02/12/09	02/12/09	Project website available		CH
<i>WORKPACKAGE 12: Dissemination</i> Objective: Inform and engage the community with the project objectives and deliverables.	01/09/09	01/02/11	Community is well informed, engaged and inspired by the project		CH NS GB MN YZ
64. Press release, blog and news items, announcement on mailing list	01/09/09	02/09/09	Announcements		CH

<i>Workpackage and activity</i>	Earliest start date	Latest completion date	Outputs (clearly indicate deliverables & reports in bold)	Milestone	Responsibility
---------------------------------	---------------------------	------------------------------	--	-----------	----------------

65. JISC project website	01/10/09	01/10/09	Copy for JISC website		CH
66. Presentation/demonstration of cataloguing tool and methodology (London)	06/10	06/10	Workshop		NS/GB/CH
67. Presentation/demonstration of cataloguing tool and methodology (Alexandria)	06/10	06/10	Workshop		MN/YZ
68. Presentation/demonstration of website and research capabilities (London)	11/10	11/10	Workshop		NS/CH
69. Presentation/demonstration of website and research capabilities (Alexandria)	11/10	11/10	Workshop		MN
70. Launch (London)	01/11	01/11	Launch event		CH
71. Launch (Alexandria)	01/11	01/11	Launch event		CH
72. Press release, blog and news items, mailing lists	02/11	02/11	Announcements		CH
<i>WORKPACKAGE 13: Evaluation</i> Objective: To monitor and document progress, successful completion of deliverables, value-for-money, usability and sustainability.	02/10	03/11	Documentation throughout project; final outsourced evaluation report.		CH
73. Formative: cataloguing software	02/10	02/10	Report (to Operational Board)		CH
74. Formative: metadata creation	06/10	06/10	Report (to Operational Board)		CH
75. Formative: website development	06/10	06/10	Report (to Operational Board)		CH
76. Summative evaluation (outsourced)	03/11	05/11	Report (to Project partners and JISC)		CH

Members of the project team

CH – Christy Henshaw
 GB – Gerhard Brey
 JT – June Tomlinson
 LA – Laurie Auchterlonie
 NS – Nikolai Serikoff

Project Acronym: WAMCP
Version: 2.0
Contact: C. Henshaw, c.henshaw@wellcome.ac.uk
Date: September 2009

MN – Magdy Nagi
RA – Richard Aspin
YZ – Youssef Zeidan

Annex C. Project team members' contact details.

Wellcome Library

183 Euston Road
London
NW1 2BE

Richard Aspin

Head of Research and Scholarship
020 7611 8480
R.aspin@wellcome.ac.uk

Christy Henshaw

Digitisation Project Manager
020 7611 7333
C.henshaw@wellcome.ac.uk

Nikolai Serikoff

Librarian (Asian collections)
020 7611 8660
N.serikoff@wellcome.ac.uk

June Tomlinson

Cataloguing and Metadata Services Manager
020 7611 8493
J.tomlinson@wellcome.ac.uk

Centre for Computing in the Humanities

King's College London
2nd Floor
26-29 Drury Lane
London
WC2B 5RL

Simon Tanner

Director of King's Digital Consultancy Service
07887 691716
Simon.tanner@kcl.ac.uk

Gerhard Brey

Fellow
020 7848 1493
Gerhard.brey@kcl.ac.uk

Bibliotheca Alexandrina

P.O.Box 138
Chatby, Alexandria
21526, Egypt

Magdy Nagi

Professor and Head of ICT Sector
+20-3-4839999
magdy.nagi@bibalex.org

Youssef Ziedan

Professor and Director of Manuscript Center
/Museum
+20-3-4820301 (Extension: 1301/1302)
youssef.ziedan@bibalex.org

Noha Adley

Professor and ICT Director
+20-3-4839999
noha.adly@bibalex.org

Annex D: Project Gantt Chart

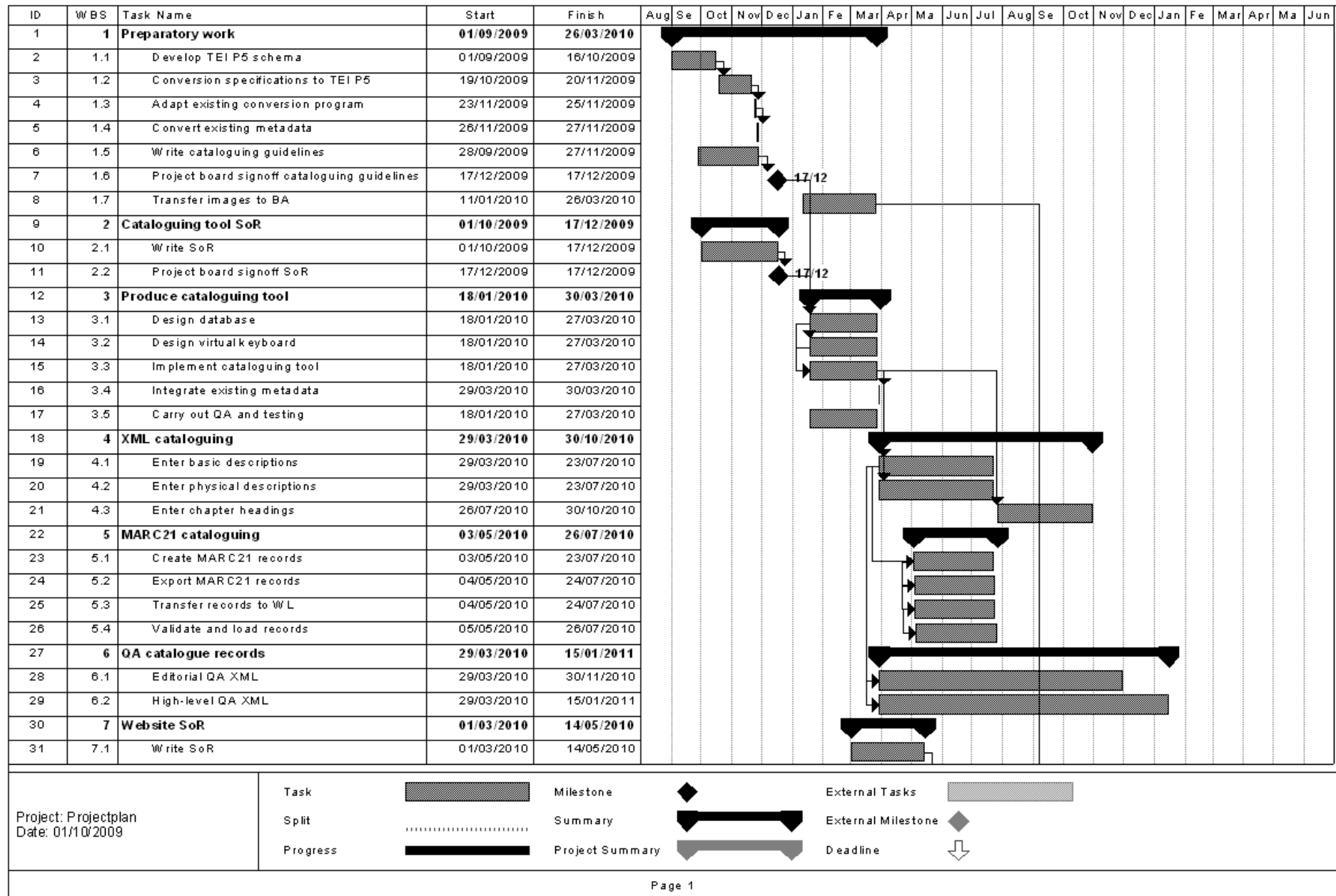

ID	WBS	Task Name	Start	Finish	Aug	Se	Oct	Nov	Dec	Jan	Fe	Mar	Apr	Ma	Jun	Jul	Aug	Se	Oct	Nov	Dec	Jan	Fe	Mar	Apr	Ma	Jun
32	7.2	Project board signoff SoR	14/05/2010	14/05/2010																							
33	8	Website design	17/05/2010	06/09/2010																							
34	8.1	Develop wireframes	17/05/2010	31/05/2010																							
35	8.2	Design image viewer	01/06/2010	05/07/2010																							
36	8.3	Design metadata display	01/06/2010	05/07/2010																							
37	8.4	Develop browsing functions	01/06/2010	05/07/2010																							
38	8.5	Develop search engine	01/06/2010	05/07/2010																							
39	8.6	Develop alternate graphical interface	01/06/2010	05/07/2010																							
40	8.7	Integration	06/07/2010	09/08/2010																							
41	8.8	Prototype with sample data	09/08/2010	09/08/2010																							
42	8.9	Test operability	10/08/2010	16/08/2010																							
43	8.10	User testing and feedback	10/08/2010	23/08/2010																							
44	8.11	Final refinement	24/08/2010	06/09/2010																							
45	8.12	Website live with sample content	06/09/2010	06/09/2010																							
46	9	Ingest and display data	07/09/2010	08/03/2011																							
47	9.1	Ingest backlog and publish	07/09/2010	05/10/2010																							
48	9.2	Ongoing archiving and dissemination	07/09/2010	08/03/2011																							
49	10	Project documents	01/10/2009	28/02/2011																							
50	10.1	Project plan completed	01/10/2009	01/10/2009																							
51	10.2	Consortium agreement signed	30/10/2009	30/10/2009																							
52	10.3	JISC progress report approved	15/06/2010	15/06/2010																							
53	10.4	JISC final report approved	21/02/2011	21/02/2011																							
54	10.5	JISC completion report approved	28/02/2011	28/02/2011																							
55	11	Project board meetings	15/12/2009	15/01/2011																							
56	11.1	December 2009	15/12/2009	15/12/2009																							
57	11.2	April 2010	15/04/2010	15/04/2010																							
58	11.3	January 2011	15/01/2011	15/01/2011																							
59	12	WL project information website	01/09/2009	02/12/2009																							
60	12.1	Commission WT web design	01/09/2009	02/09/2009																							
61	12.2	Develop wireframe	01/10/2009	15/10/2009																							
62	12.3	Write website content	16/10/2009	02/11/2009																							

Project: Projectplan Date: 01/10/2009	Task		Milestone		External Tasks	
	Split		Summary		External Milestone	
	Progress		Project Summary		Deadline	

ID	WBS	Task Name	Start	Finish	Aug	Se	Oct	Nov	Dec	Jan	Fe	Mar	Apr	Ma	Jun	Jul	Aug	Se	Oct	Nov	Dec	Jan	Fe	Mar	Apr	Ma	Jun
63	12.4	Create website	03/11/2009	02/12/2009																							
64	12.5	Website live	02/12/2009	02/12/2009																							
65	13	Dissemination	01/09/2009	01/02/2011																							
66	13.1	Press release	01/09/2009	02/09/2009																							
67	13.2	JISC project website	01/10/2009	02/10/2009																							
68	13.3	Cataloguing tool demo (London)	30/06/2010	01/07/2010																							
69	13.4	Cataloguing tool demo (Alexandria)	30/06/2010	01/07/2010																							
70	13.5	Website demo (London)	30/11/2010	01/12/2010																							
71	13.6	Website demo (Alexandria)	01/11/2010	02/11/2010																							
72	13.7	Launch (London)	31/01/2011	01/02/2011																							
73	13.8	Launch (Alexandria)	31/01/2011	01/02/2011																							
74	13.9	Press release	31/01/2011	01/02/2011																							
75	14	Evaluation	15/02/2010	15/05/2011																							
76	14.1	Formative: Cataloguing software	15/02/2010	16/02/2010																							
77	14.2	Formative: metadata creation	15/06/2010	16/06/2010																							
78	14.3	Formative: website development	15/06/2010	16/06/2010																							
79	14.4	Summative	15/03/2011	15/05/2011																							



Project: Projectplan Date: 01/10/2009	Task		Milestone		External Tasks	
	Split		Summary		External Milestone	
	Progress		Project Summary		Deadline	